

FREEMOTION[®]

LAT PULLDOWN/HIGH ROW

Model No. GD502.0

Serial No. _____

Write the serial number in the space above for reference.

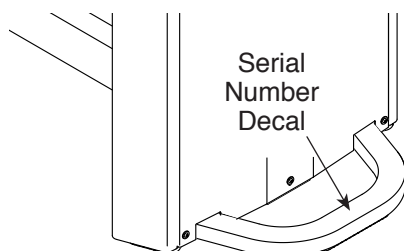

OWNER'S MANUAL

QUESTIONS?

If you have questions, or if parts are damaged or missing, please see **HOW TO CONTACT CUSTOMER CARE** on the back cover of this manual.

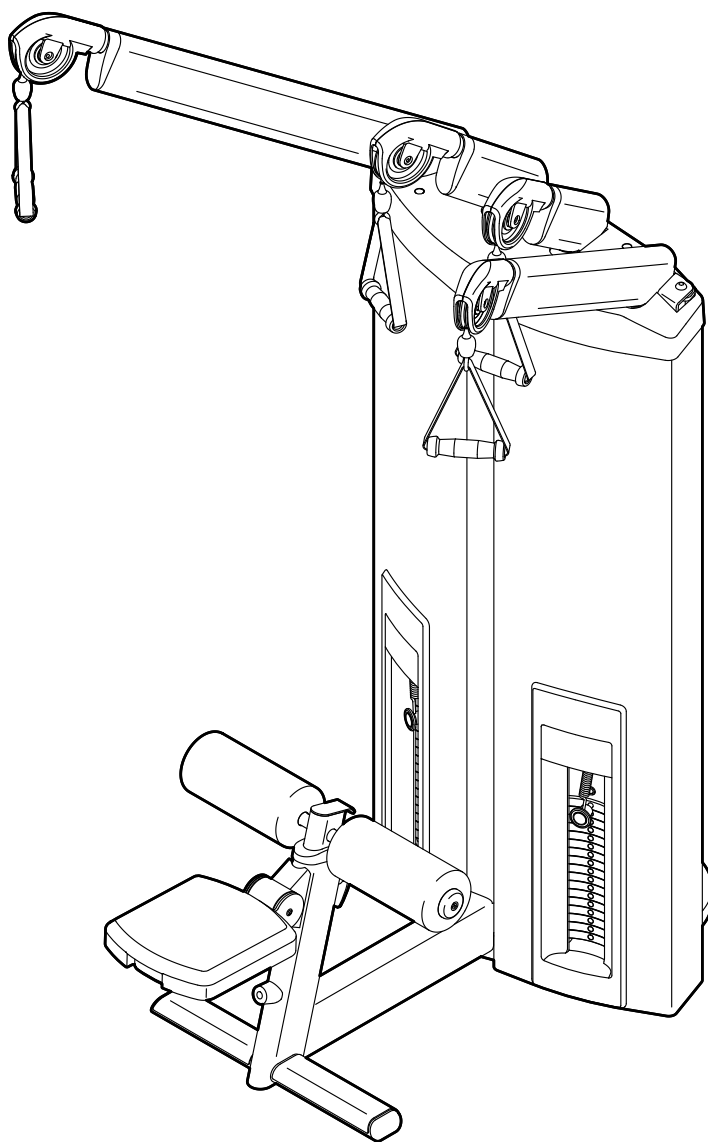

CAUTION

Read all precautions and instructions in this manual before using this equipment. Keep this manual for future reference.

TABLE OF CONTENTS

IMPORTANT PRECAUTIONS.....	3
WARNING DECAL PLACEMENT.....	4
BEFORE YOU BEGIN.....	5
ASSEMBLY.....	6
ADJUSTMENT.....	16
MAINTENANCE AND TROUBLESHOOTING.....	17
CABLE DIAGRAM.....	20
PART LIST.....	21
EXPLODED DRAWING.....	22
HOW TO CONTACT CUSTOMER CARE.....	Back Cover
LIMITED WARRANTY.....	Back Cover

FORMULA 409 is a registered trademark of The Clorox Company.
SIMPLE GREEN is a registered trademark of Sunshine Makers, Inc.
Teflon is a registered trademark of E. I. du Pont de Nemours and Company.
FREEMOTION is a registered trademark of ICON Health & Fitness, Inc.

IMPORTANT PRECAUTIONS

⚠️ WARNING: To reduce the risk of serious injury, read all important precautions and instructions in this manual and all warnings on the strength equipment before using the strength equipment. Freemotion Fitness assumes no responsibility for personal injury or property damage sustained by or through the use of this product.

1. It is the responsibility of the owner to ensure that all users of the strength equipment are adequately informed of all precautions, have read and understood all warning and caution labels, and are informed of how to use the strength equipment properly.
2. All users of the strength equipment should be instructed to report any injury or strength equipment irregularity to facility staff immediately.
3. Before beginning any exercise program, consult your physician. This is especially important for persons over age 35 or persons with pre-existing health problems.
4. Use the strength equipment only as described in this manual.
5. Use the strength equipment only on a level surface. Cover the floor beneath the strength equipment to protect the floor.
6. It is the responsibility of the owner to ensure that there is enough space around the strength equipment for the intended exercise.
7. Using the anchor holes (see page 5), anchor the strength equipment to the floor to provide maximum stability.
8. Keep children under age 13 and pets away from the strength equipment at all times.
9. Always wear athletic shoes for foot protection while exercising.
10. The strength equipment is designed to support a maximum user weight of 400 lbs. (182 kg).
11. Keep hands and feet away from moving parts. Do not lean on or rest your hands on the strength equipment while it is in use.
12. Make sure that the weight pins are completely inserted into the desired weights or the weight carriage. Always insert the weight pins; do not use the strength equipment without inserting the weight pins.
13. Make sure that the handles are attached securely before each use of the strength equipment.
14. Check all cables, cable connections, and pulleys before each use of the strength equipment. Make sure that all parts are properly tightened. Replace any worn parts immediately.
15. Make sure that the cables remain on the pulleys at all times. If a cable binds while you are exercising, stop immediately and make sure that the cable is on the pulleys and that nothing is interfering with the cable or the pulleys.
16. Over exercising may result in serious injury or death. If you feel faint, if you become short of breath, or if you experience pain while exercising, stop immediately and cool down.

WARNING DECAL PLACEMENT

This drawing shows the location(s) of the warning decal(s). **If a decal is missing or illegible, see the back cover of this manual and request a free replacement decal. Apply the decal in the location shown.** Note: The decal(s) may not be shown at actual size.

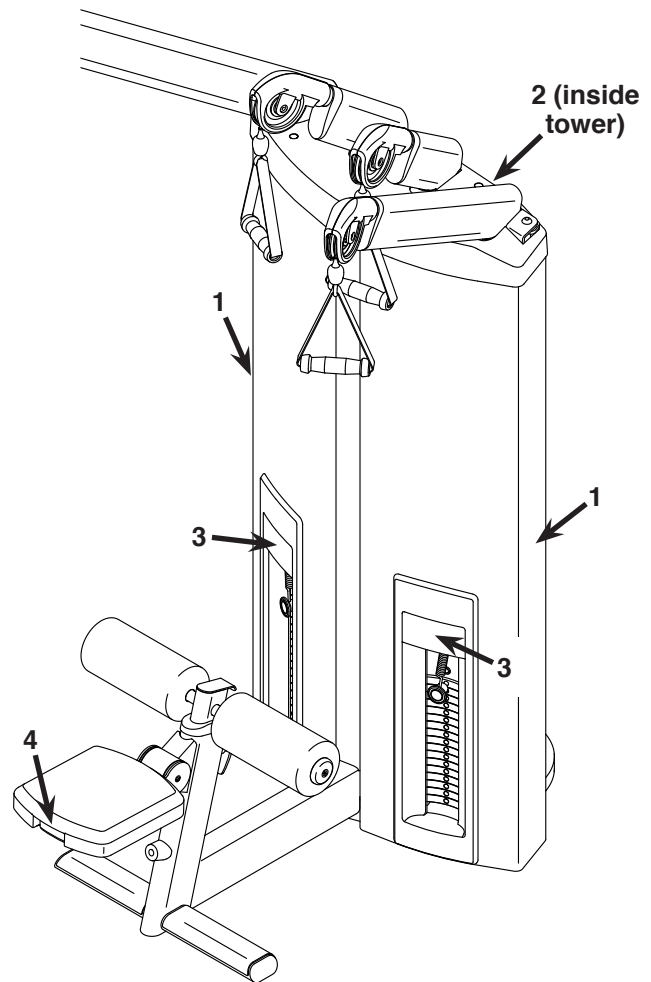

Decal 1



Decal 2

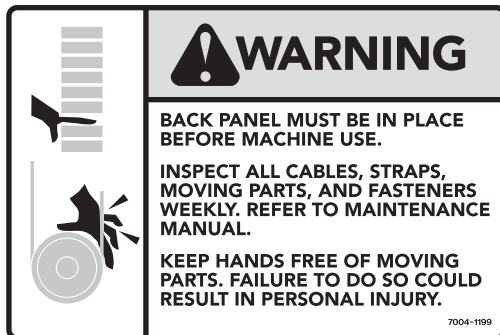

Decal 3

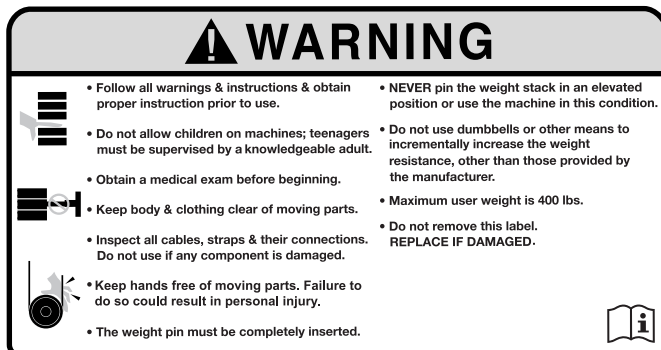

Decal 4



BEFORE YOU BEGIN

Thank you for selecting the innovative FREEMOTION® LAT PULLDOWN/HIGH ROW strength equipment. With unrestricted motion, the LAT PULLDOWN/HIGH ROW strength equipment enables you to work your body's muscle groups together—the same way you do naturally—to train more effectively.



For your benefit, read this manual carefully before using the strength equipment. If you have questions

after reading this manual, please see the back cover of this manual. To help us assist you, note the product model number and serial number before contacting us. The model number and the location of the serial number decal are shown on the front cover of this manual.

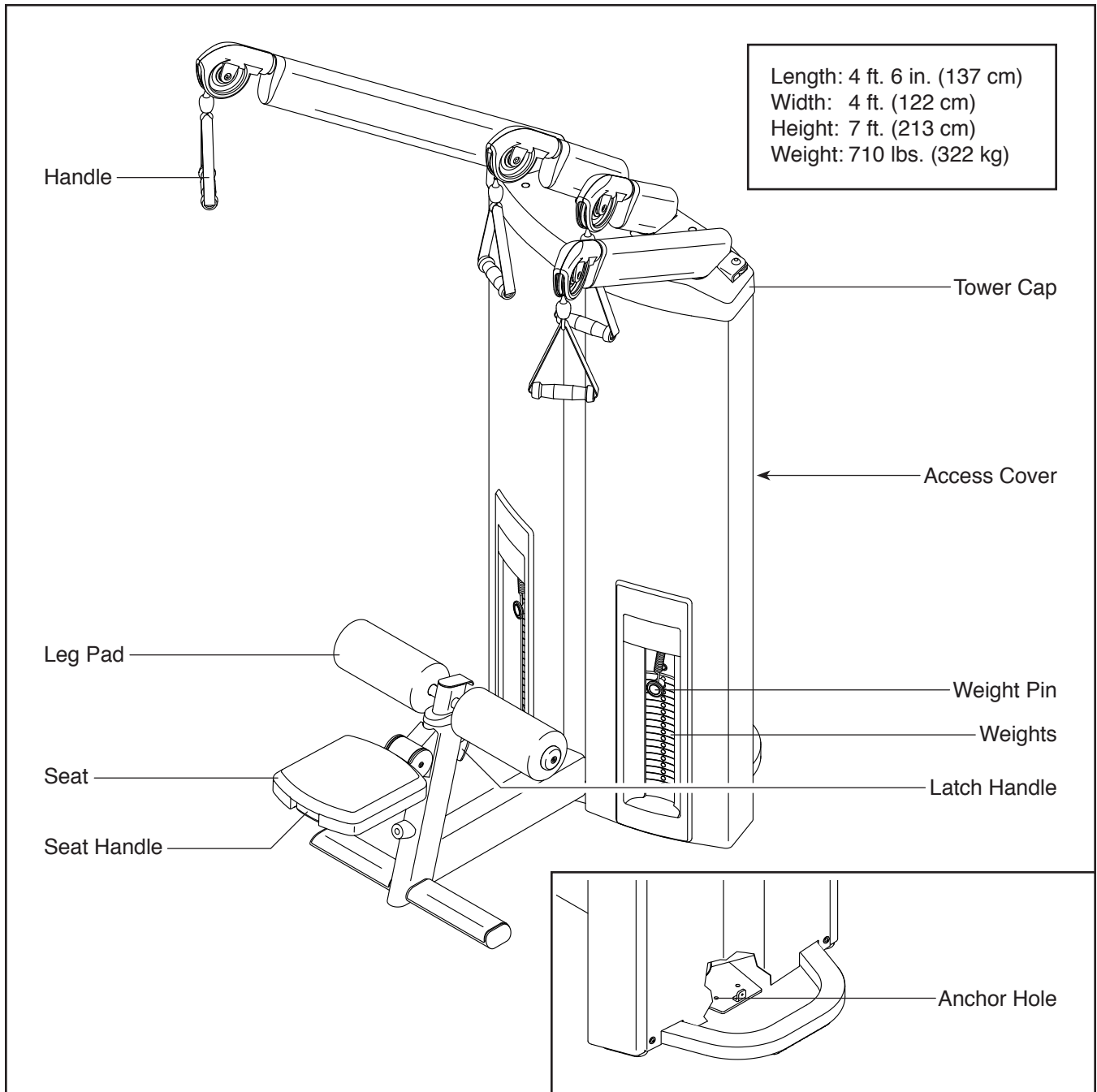
Before reading further, please review the drawing below and familiarize yourself with the parts that are labeled.



ASSEMBLY

- Assembly requires two persons.
 - Because of its weight and size, assemble the strength equipment in the location where it will be used. Make sure that there is enough clearance around the strength equipment.
 - Place all parts in a cleared area and remove the packing materials. Do not dispose of the packing materials until assembly is completed.
- The following tools (not included) are required for assembly:
 - a set of metric hex keys 
 - one adjustable wrench 
- Assembly may be more convenient if you have your own set of wrenches. To avoid damaging parts, do not use power tools.

1. **IMPORTANT:** During steps 1–6, set the parts that you remove in separate piles. You will reattach the parts in later steps.

Remove the six M6 x 10mm Screws (32), the six M6 Large Washers (40), and the Access Cover (17) from the Tower (45).

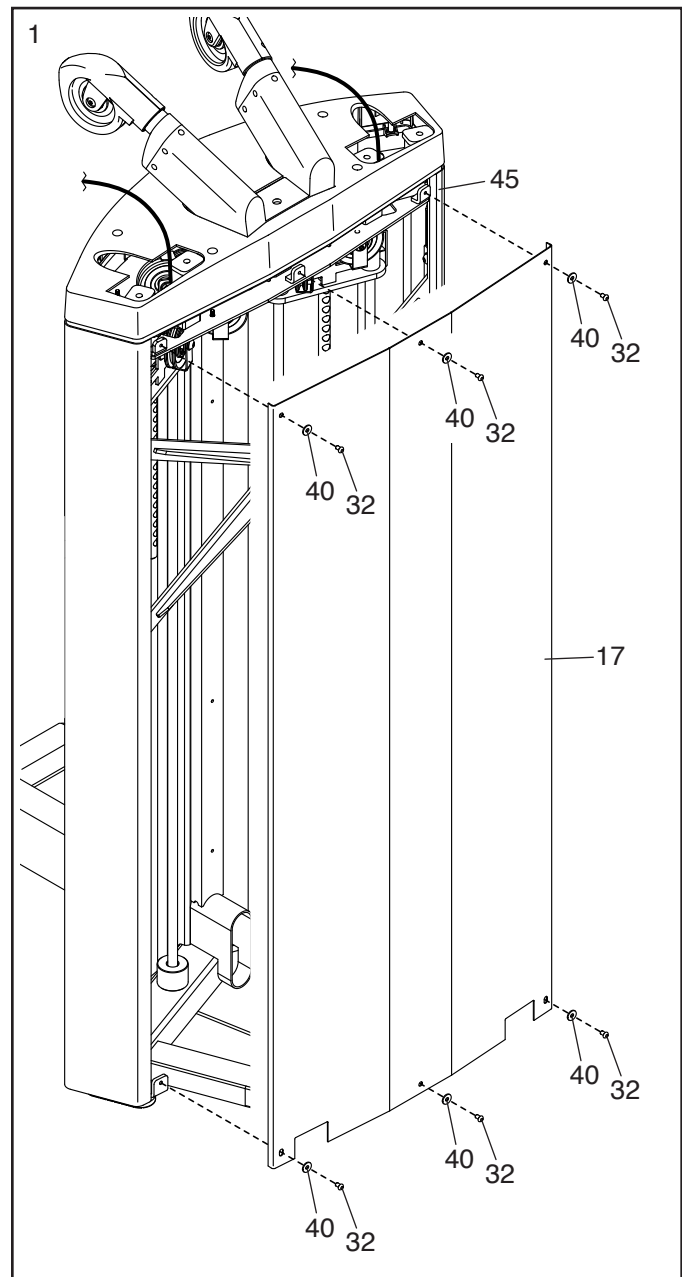

2. Remove the eight M10 x 20mm Screws (77) and the Tower Brace (51).

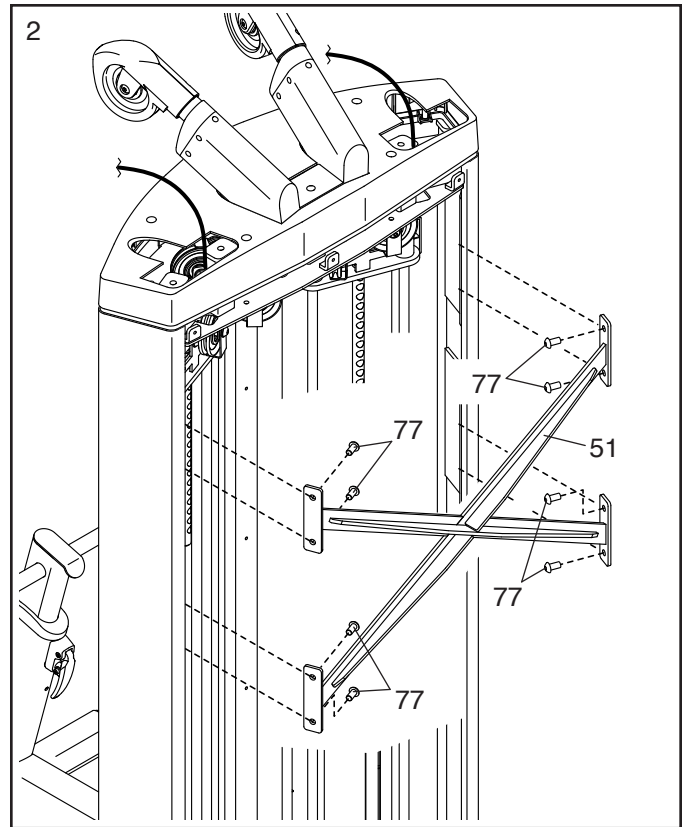

3. Remove the four M6 x 16mm Screws (27) and the four M6 Washers (81) from the Tower Cap (13).

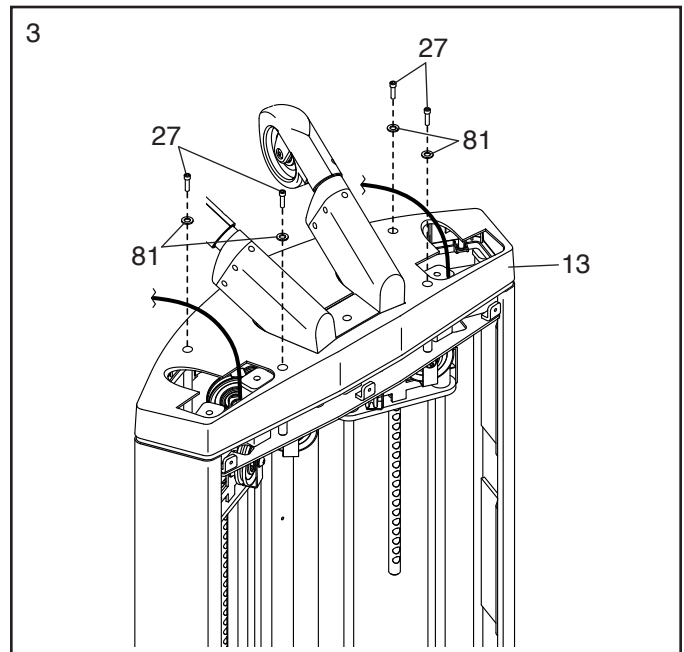

4. Have a second person hold the Center Pulley Frame (46). Remove the three M12 x 20mm Screws (76) from the Center Pulley Frame.

Then, lift the Center Pulley Frame (46) and the Tower Cap (13) off the Tower (45), and carefully hang the Center Pulley Frame and the Tower Cap against the front of the Tower. **Be careful to avoid damaging the Tower Cap, the Tower, or the Cables (57).**

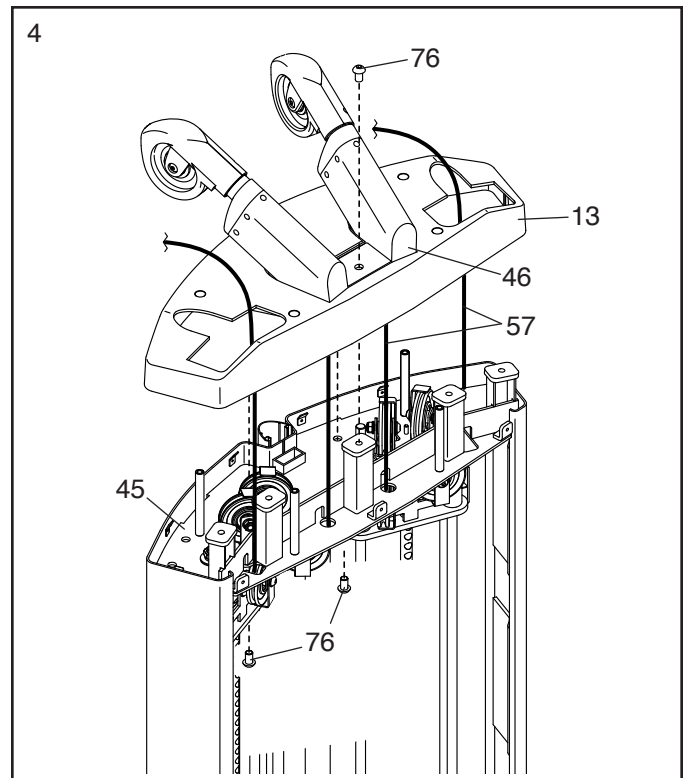

5. Remove the two M16 Jam Nuts (37), the two M16 Split Washers (38), the two Weight Guide Spacers (10), and the two Plastic Washers (11) from the upper ends of the two Weight Guides (9) on one side of the Tower (45).

Note: After you remove these parts, the Weight Guides (9) will slide downward a few inches into the Tower (45).

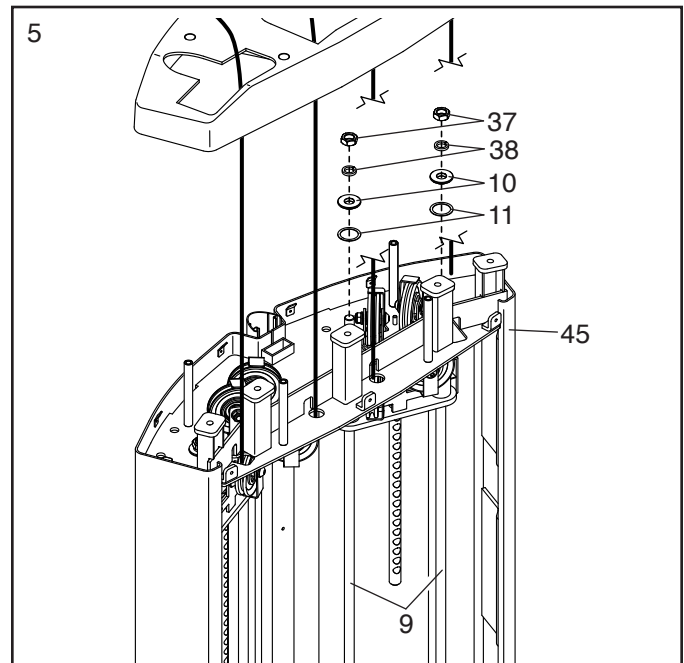

6. Pull the upper ends of the two Weight Guides (9) toward you. Remove the remaining Plastic Washers (11), Weight Guide Spacers (10), M16 Split Washers (38), and M16 Jam Nuts (37) from the Weight Guides.

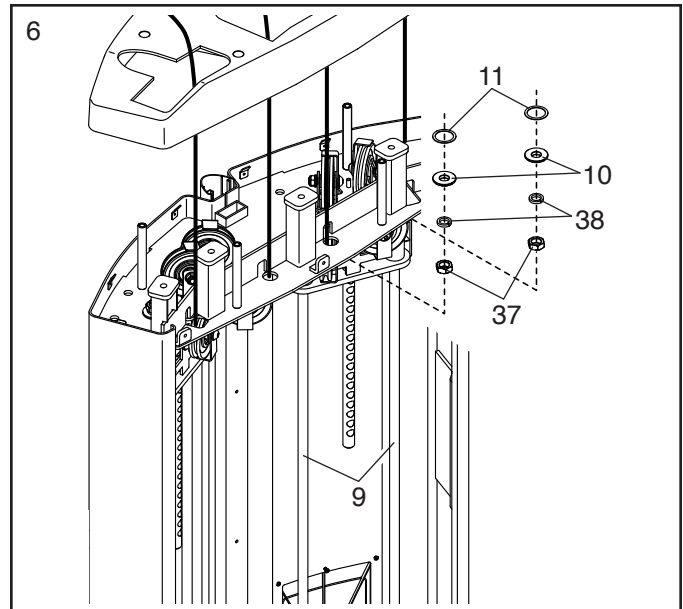

7. Hold the Weight Carriage (1), and cut the plastic tie (not shown) securing the Weight Carriage to the Tower (45). Then, slide the Weight Carriage upward off the Weight Guides (9).

Next, look at the decals on one of the stacks of Weights (4), and find the decal that has the **largest** number on it. Orient that Weight as shown at the right, and slide it onto the Weight Guides (9).

Repeat this step with the remaining 16 Weights (4) in the stack. **Then, look at the decals on all the Weights, and make sure that the Weights are in the correct order.**

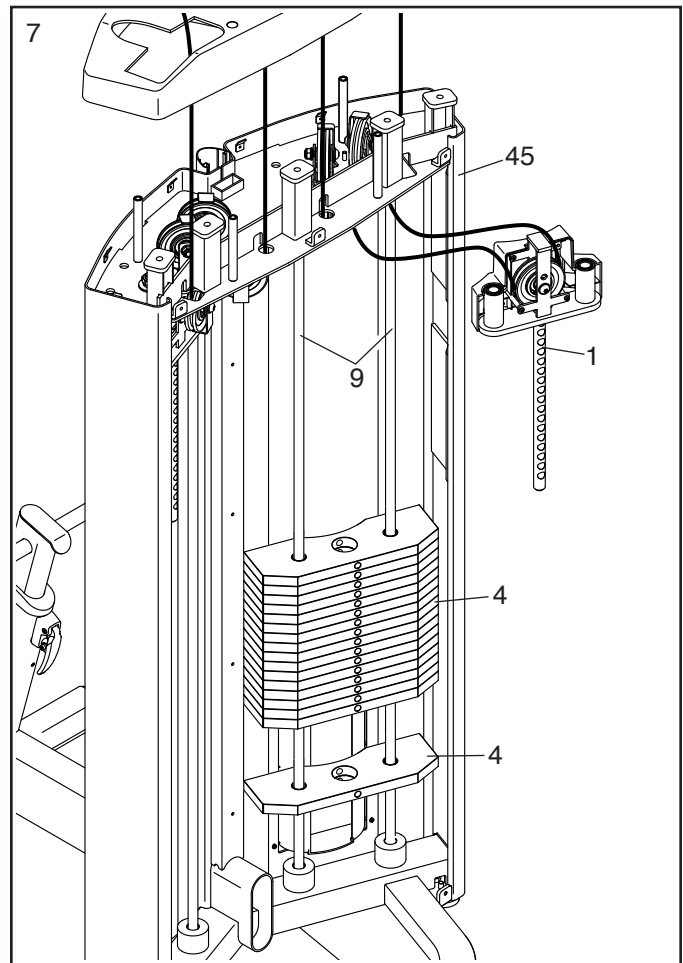

8. Slide the Weight Carriage (1) onto the Weight Guides (9), and rest the Weight Carriage on the stack of Weights (4).

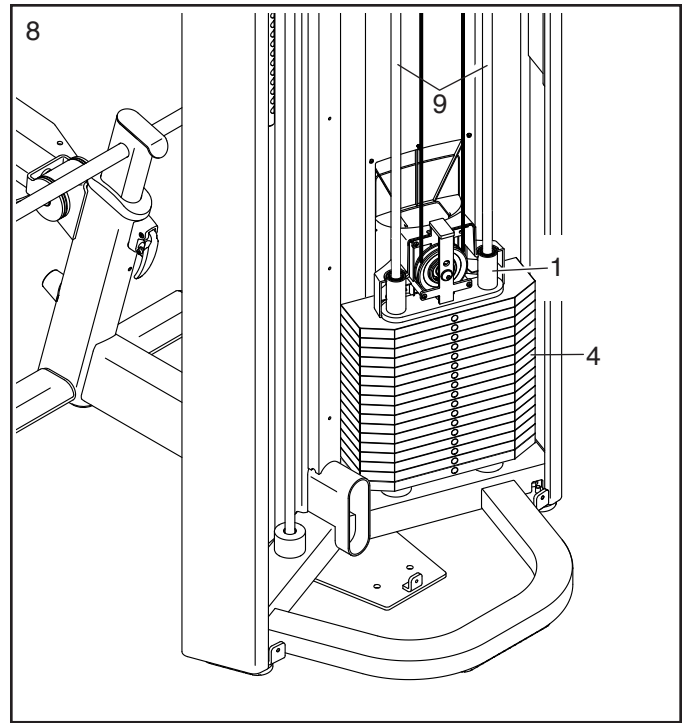

9. Note: This step requires the parts that you removed in step 6.

Pull the upper ends of the Weight Guides (9) toward you. Tighten the two M16 Jam Nuts (37) as far as possible onto the Weight Guides.

Then, slide the two M16 Split Washers (38), the two Weight Guide Spacers (10), and the two Plastic Washers (11) onto the Weight Guides (9). **Make sure that the Weight Guide Spacers are oriented as shown in the inset drawing.**

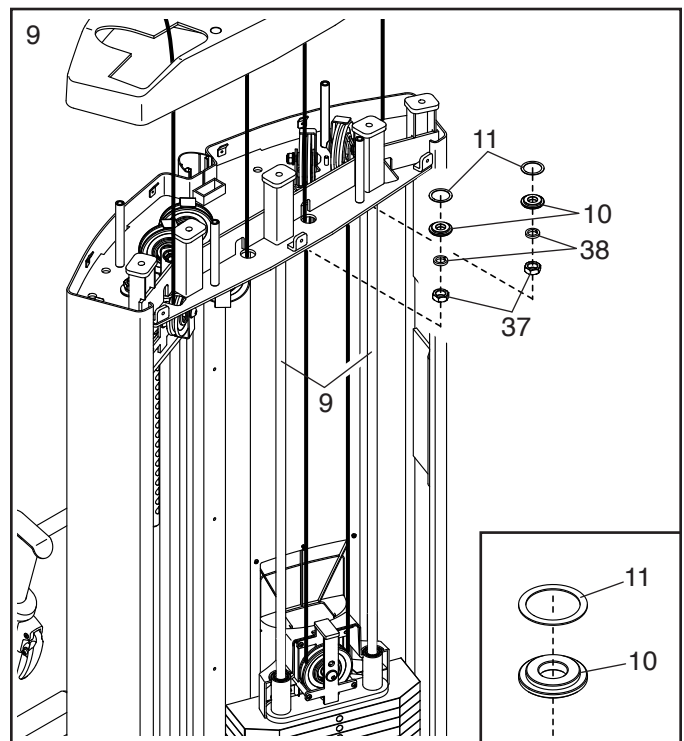

10. Note: This step requires the parts that you removed in step 5.

Lift the Weight Guides (9) a few inches. Slide the two Plastic Washers (11), the two Weight Guide Spacers (10), and the two M16 Split Washers (38) onto the Weight Guides. **Make sure that the Weight Guide Spacers are oriented as shown in the inset drawing. In addition, make sure that the Weight Guide Spacers are pressed into the indicated round holes (A).**

Then, tighten the two M16 Jam Nuts (37) onto the Weight Guides (9).

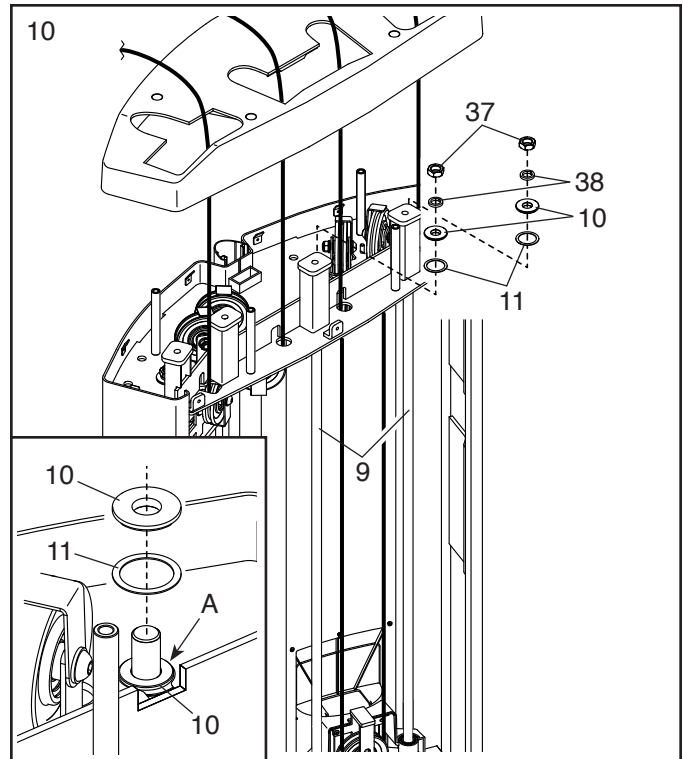

11. Repeat steps 5–10 on the other side of the strength equipment.

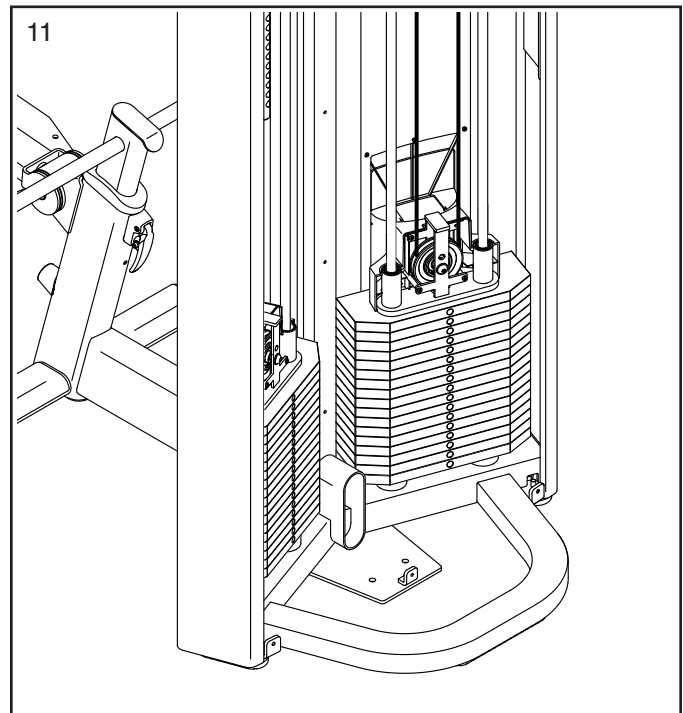

12. Note: This step requires the parts that you removed in step 4.

Hold the Tower Cap (13) and the Center Pulley Frame (46) near the top of the Tower (45). **Make sure that the Cables (57) are centered on the four Medium Pulleys (2) on the Tower.**

Insert the excess Cable (57) downward into the Tower (45), and carefully set the Tower Cap (13) and the Center Pulley Frame (46) on the Tower.

Attach the Center Pulley Frame (46) with the three M12 x 20mm Screws (76); **start all three Screws, and then tighten them.**

Then, set the Left and Right Pulley Frames (47, 48) on the Tower Cap (13) and attach them to the Tower (45) with eight M12 x 20mm Screws (76); **start all eight Screws, and then tighten them.**

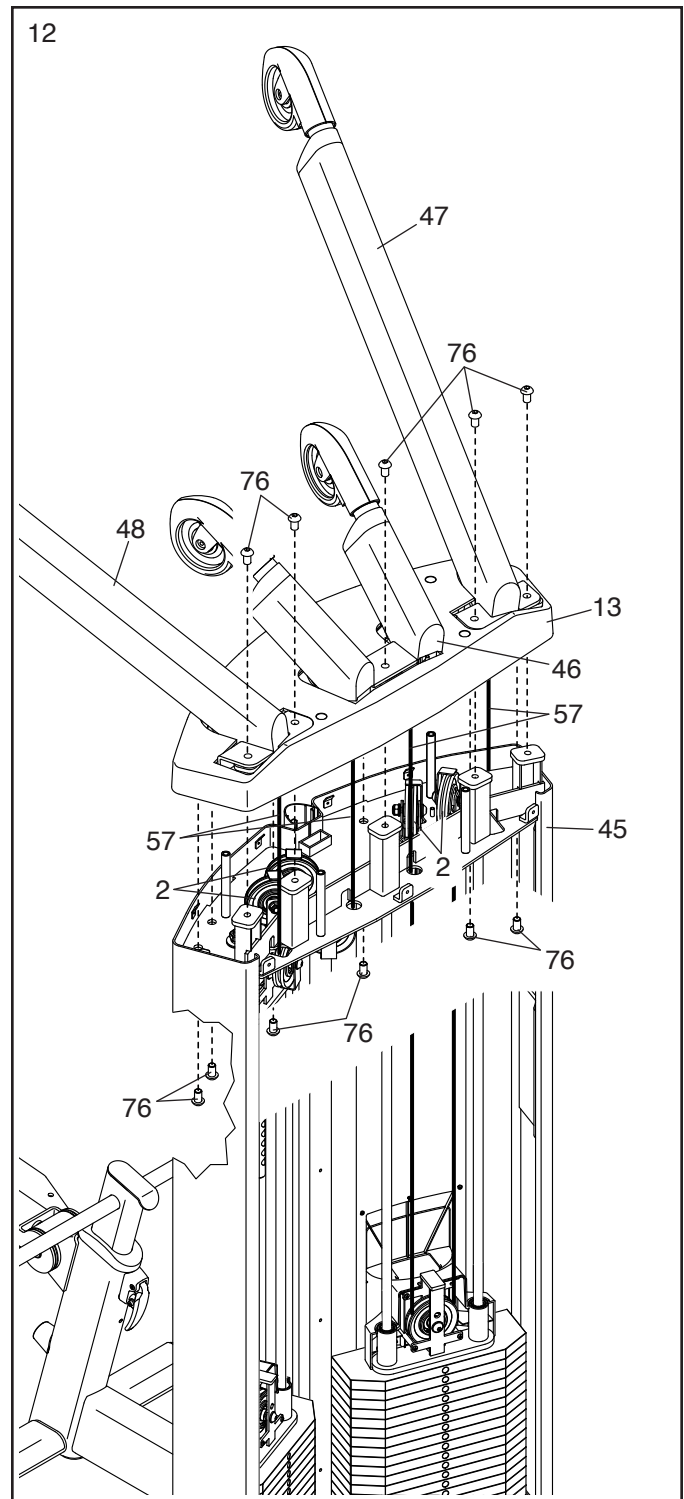

13. Note: This step requires the parts that you removed in step 3.

Attach the Tower Cap (13) to the Tower (45) with the four M6 x 16mm Screws (27) and the four M6 Washers (81); **start all four Screws, and then tighten them.**

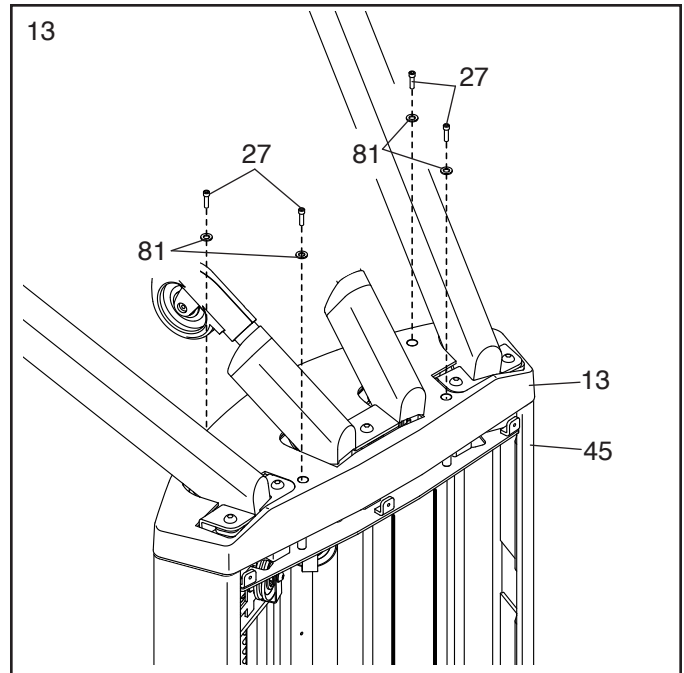

14. Note: This step requires the parts that you removed in step 2.

Attach the Tower Brace (51) to the Tower (45) with the eight M10 x 20mm Screws (77); **start all eight Screws, and then tighten them.**

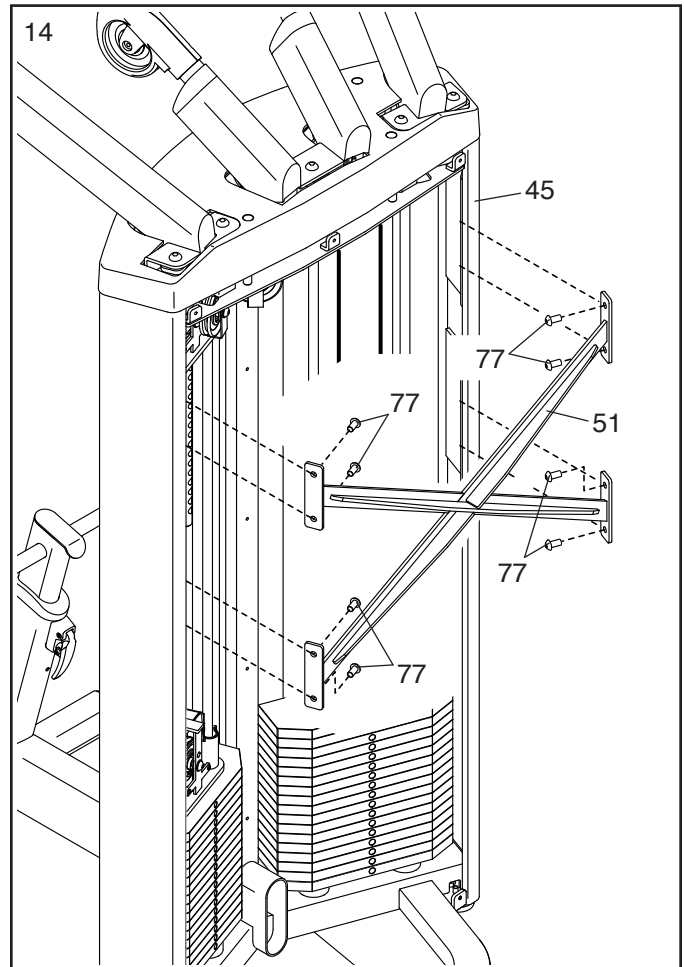

15. Note: This step requires the parts that you removed in step 1.

Attach the Access Cover (17) to the Tower (45) with the six M6 x 10mm Screws (32) and the six M6 Large Washers (40); **start all six Screws, and then tighten them.**

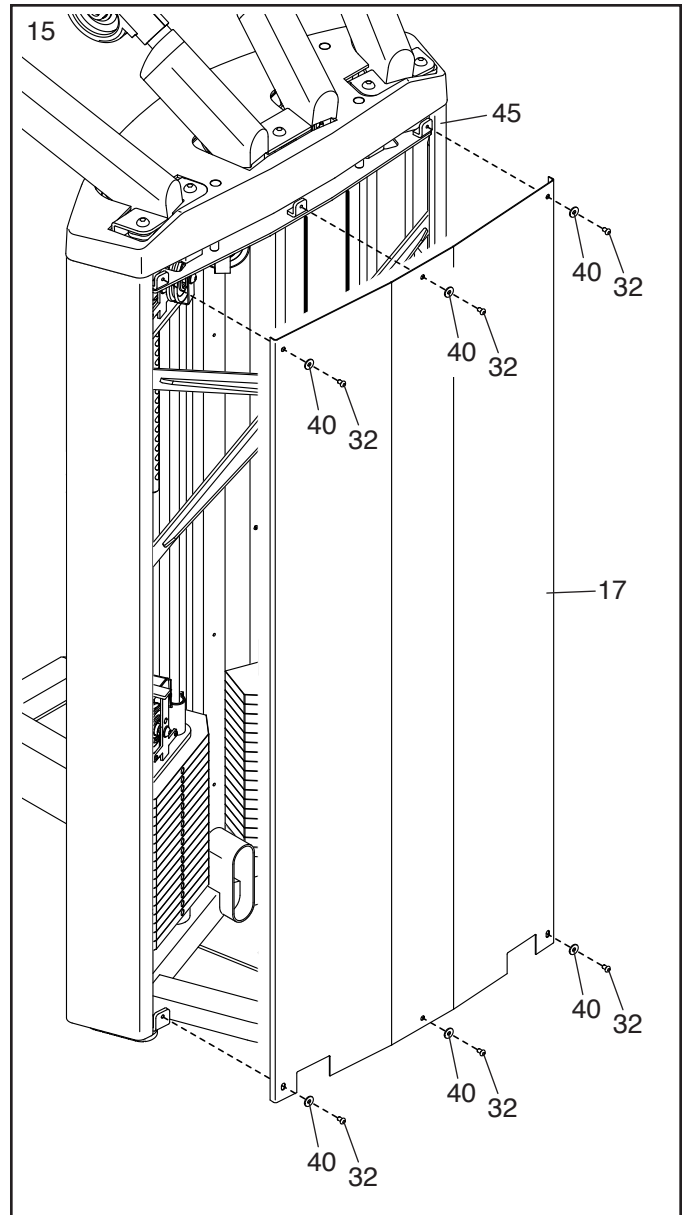

16. Attach the Seat (55) to the Seat Frame (49) with four M8 x 30mm Screws (78); **start all four Screws, and then tighten them.**

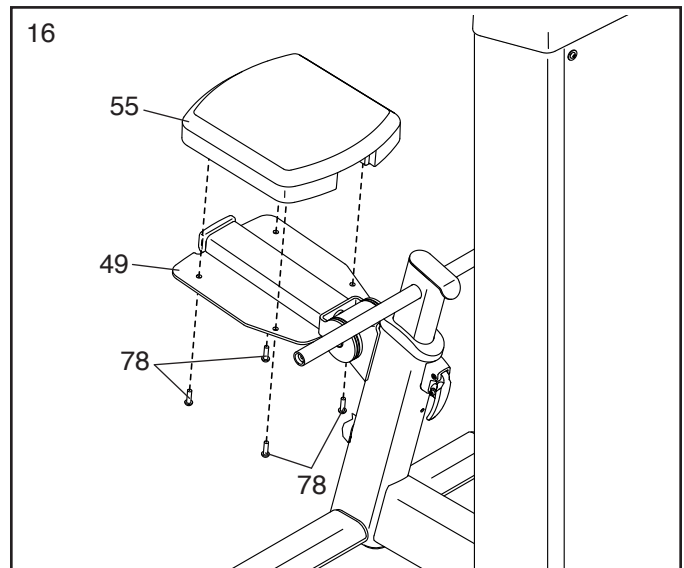

17. Slide a Leg Pad (52) onto each side of the Leg Frame (50). Attach each Leg Pad with an M6 x 25mm Screw (80) and a Leg Pad Cap (66).

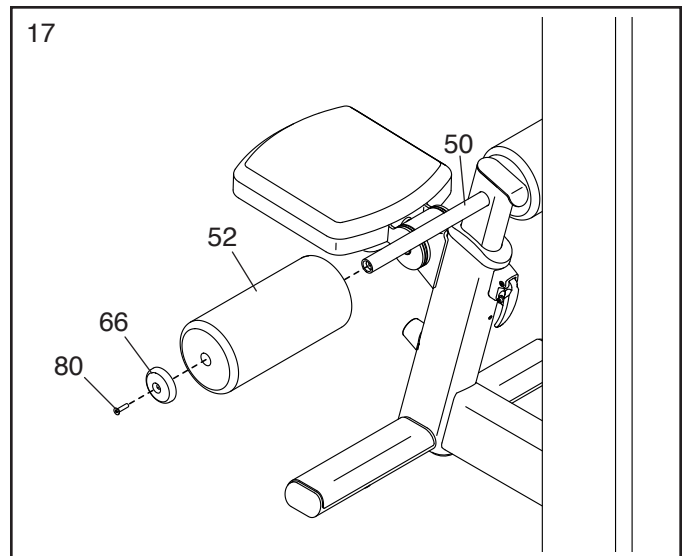

18. **Make sure that all parts of the strength equipment are properly tightened.** To protect the floor or carpet from damage, place a mat under the strength equipment.

ADJUSTMENT

This section explains how to adjust the strength equipment. **Make sure that all parts are properly tightened each time the strength equipment is used. Replace any worn parts immediately.**

ADJUSTING THE RESISTANCE

To change the resistance setting of each weight stack, insert the weight pin (A) into the desired weight (B) or into the weight carriage (C). **Make sure to fully insert the weight pin. Do not use the strength equipment without inserting the weight pins.**

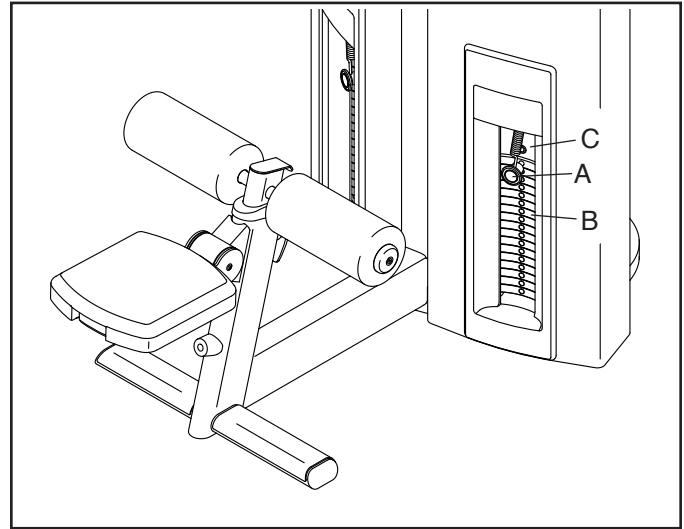

RAISING AND LOWERING THE SEAT

To use the seat, raise the seat until you hear the seat pin (not shown) snap into the indicated hole (D). **Then, try to move the seat upward and downward slightly to make sure that the seat pin is engaged in the hole.**

For exercises that do not require the seat, pull the seat handle (E), lower the seat, and then release the seat handle.

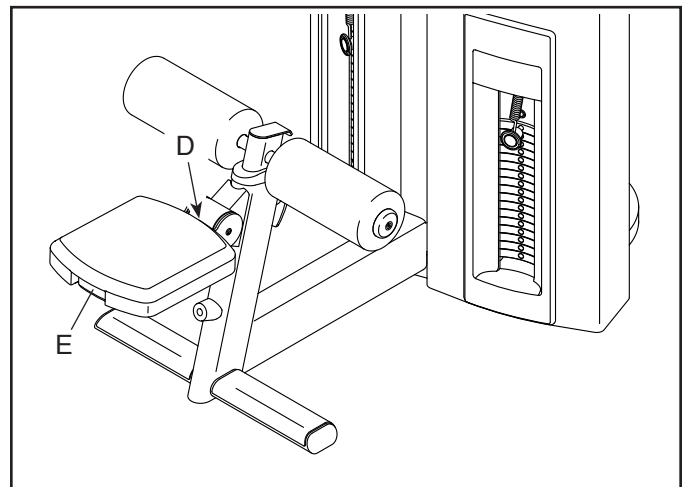

RAISING AND LOWERING THE LEG FRAME

To adjust the leg frame (F), pull the latch handle (G), raise or lower the leg frame to the desired position, and then release the latch handle. **Then, try to move the leg frame upward and downward slightly to make sure that the leg frame pin (not shown) is engaged in an adjustment hole in the leg frame.**

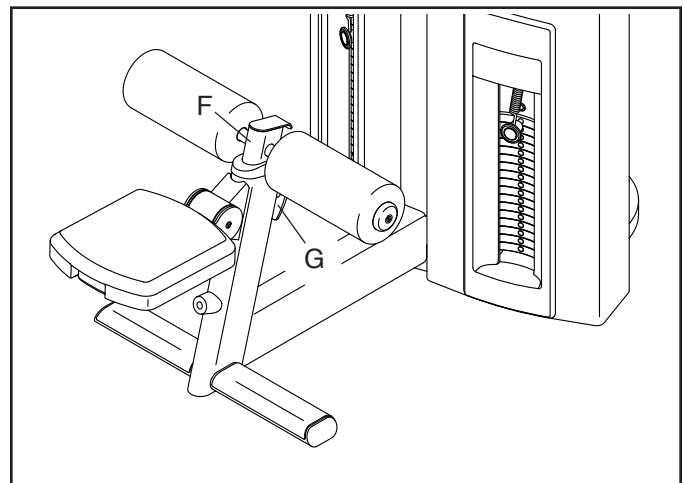

MAINTENANCE AND TROUBLESHOOTING

For optimal performance of the strength equipment and to reduce the chances of injury to users, you must perform preventive maintenance on a regular basis. Instruct all personnel to perform the procedures described in this section. Personnel must also record and report any accident. To maintain the strength equipment's warranty, use only FREEMOTION parts for repair or replacement. If there are any questions or concerns, see HOW TO CONTACT CUSTOMER CARE on the back cover of this manual.

DAILY MAINTENANCE

General Cleaning

Clean the strength equipment using a soft cloth dampened with mild soap and warm water. If necessary, use a soft bristle brush with the cleaning solution.

Then, rinse the strength equipment using a soft cloth dampened with clean water, and thoroughly dry it.

Difficult Stains

Spray the stain with a non-abrasive household cleaner such as FORMULA 409®, SIMPLE GREEN®, or a similar product. Rub the stained area gently and then let the cleaning solution sit for a few minutes.

Then, rinse the strength equipment using a soft cloth dampened with clean water, and thoroughly dry it.

If necessary, repeat these steps using a soft bristle brush.

Optional Method for Difficult Stains

Rub the stained area gently using a soft cloth dampened with rubbing alcohol.

Then, rinse the strength equipment using a soft cloth dampened with clean water, and thoroughly dry it.

CAUTION: Follow the directions and the safety precautions of the manufacturer of each cleaning product used. Freemotion Fitness and its vendors cannot be held liable for injuries or damage resulting from the use or misuse of cleaning products. **IMPORTANT:** When using any cleaning product, try it first in a hidden place to ensure that there is no damage to the material. Do not use abrasive cleaners; strong cleaners; or solvents such as lacquer thinner, kerosene, gasoline, or similar liquids. Such substances may scratch the strength equipment, damage plastic parts and decals, or cause other damage.

WEEKLY MAINTENANCE

Hardware

Check all nuts, bolts, and screws, and tighten them if necessary. Replace any worn parts immediately.

IMPORTANT: All cushions have dense plywood supports with tee-nuts that are used to attach the cushions to the strength equipment. Because the tee-nuts are held by the plywood, they will not withstand the torque that standard nuts will. When tightening the bolts or screws securing a cushion, turn them only until they are snug and the cushion does not move or feel loose. Overtightening may strip the tee-nuts from the plywood and make it impossible to remove the cushion in the future. Note: Your strength equipment may not have cushions.

Cable Inspection

To inspect the cables, first remove the screws and the access cover from the back of the strength equipment. Next, check the entire length of each cable by slowly performing one repetition on the strength equipment. Inspect the cable on the exterior of the strength equipment and the cable on the interior. Run your fingers along the cable, paying close attention at the bends and attachment points. Watch for the following conditions, which may indicate a worn cable that should be replaced:

- A. a torn or split sheath that exposes the cable
- B. a kinked or severely bent cable
- C. a curled or twisted sheath
- D. a stretched sheath with a thinning cross-section

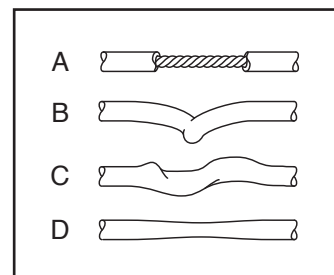

Then, reattach the access cover.

Cable Traps

To inspect the cable traps (A), first remove the screws and the tower cap from the top of the strength equipment. Next, remove the screws and the access cover from the back of the strength equipment. Then, check the cable traps to ensure that they are not rubbing (B) against the cables and that they are holding the cables in the grooves of the pulleys. If a cable trap is incorrectly aligned (C), loosen the locknut slightly, readjust the cable trap as necessary, and then retighten the locknut. Then, reattach the access cover and the tower cap.

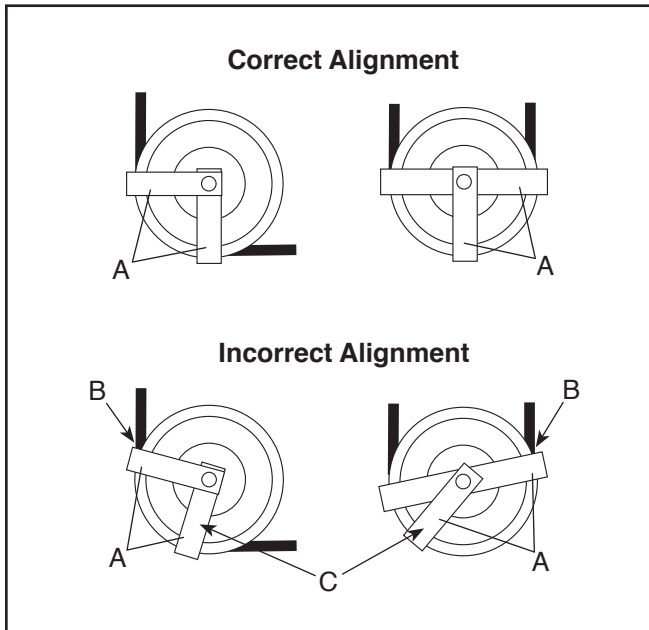

MONTHLY MAINTENANCE

Grips

Check the grips and replace them if needed.
Note: Your strength equipment may not have grips.

Weight Guide Lubrication

To lubricate the weight guides, first remove the screws and the access cover from the back of the strength equipment. Next, clean and lubricate each weight guide inside the tower by wiping it with a soft cloth containing 10W-40 or 10W-30 lightweight motor oil. Apply only a light coating over the entire length of the weight guide. **Do not use TEFLON®-based lubricants.** Then, reattach the access cover.

CABLE ADJUSTMENT

For the strength equipment to function properly, the cables must be tensioned correctly. To check the tension of each cable, slowly raise and lower the applicable weight carriage by performing one repetition.

If there is not enough tension on a cable, the weight carriage will not be lifted immediately when the repetition is begun. Ideally, the cable should not move more than 1/2 in. (1.3 cm) from the resting position before the weight carriage is lifted.

If there is not enough tension on a cable, adjust the cable as described below.

IMPORTANT: Make this adjustment only if there is slack in a cable. This adjustment is only for increasing the cable tension, because it involves shortening the cable.

Tools required: 1/8" hex key, cable cutters, torque wrench, utility knife

1. To create slack in the cable, first remove the weight pin, pull a handle out several inches, and then insert the weight pin into the third weight and into the hole in the lower end of the weight carriage.
2. Push the black rubber cable stop (D) off the cable eyelet (E) as shown.

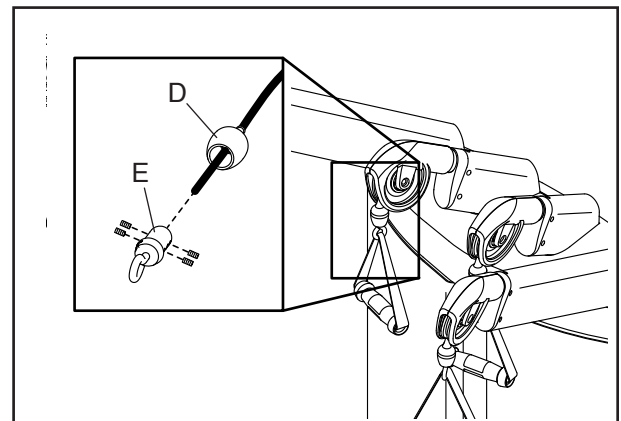

3. Loosen the four set screws in the cable eyelet (E), and pull out the end of the cable. Note: For clarity, the drawing shows the set screws removed; however, it is not necessary to remove the set screws.

4. Using cable cutters, cut off 1 in. (2.5 cm) of the end of the cable. **IMPORTANT:** Other tools may flatten or bend the cable strands so that it may be difficult for you to reinsert the cable into the cable eyelet (E).
5. Cut off 1 in. (2.5 cm) of the black sheath from the end of the cable.
6. Reinsert the cable and the sheath into the cable eyelet (E) so that all of the bare cable is in the hole.
7. Retighten the four set screws equally until they contact the cable. Then, tighten each set screw alternately 1/4 turn, until all are set to 85 inch/pounds (9.6 Newton-meters).
8. Slide the cable stop (D) onto the cable eyelet (E), remove the weight pin, and return the handle to the resting position.
9. Check for proper tension on the cable as described in CABLE ADJUSTMENT on page 18.

WEIGHT STACK SERVICING

Servicing the weight stack involves replacing the bushings in the weight carriages. To order bushings, see HOW TO CONTACT CUSTOMER CARE on the back cover of this manual.

Follow the steps below to service each weight stack.
Tools required: hammer, punch, piece of scrap wood

1. Remove the screws and the tower cap from the top of the strength equipment. Next, remove the screws and the access cover from the back of the strength equipment.
2. Remove the nuts and washers from the upper ends of the weight guides, and let the weight guides slide down to the floor.
3. Slide the weight carriage upward off the tops of the weight guides. Note: For increased clearance, pull the weight guides toward the back of the strength equipment.

4. Using a punch, drive the four old bushings (F) out of the weight carriage.
5. Hold one of the new bushings (F) square with the face of one of the holes in the weight carriage, place a piece of scrap wood on top of the bushing, and tap the bushing into place until the bushing is flush with the hole in the weight carriage. **Insert the other three new bushings (F) in the same way.**

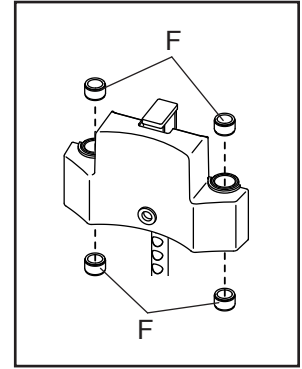

6. Clean and lubricate the weight guides by wiping them with a soft cloth containing 10W-40 or 10W-30 lightweight motor oil. Apply only a light coating over the entire length. **Do not use TEFLON®-based lubricants.**
7. Slide the weight carriage onto the weight guides.
8. Reattach the weight guides to the top of the tower with the nuts and washers.
9. Insert the weight pin into the weight carriage. Pull the handle, lifting the weight carriage all of the way to the top. Then, slowly return the handle to the resting position.

If the weight carriage sticks, loosen the nuts on the upper end of one of the weight guides. Then, lift the weight carriage to the top again, and retighten the nuts. Check the full travel again and readjust the weight guides if necessary.

10. Slowly perform a repetition and have someone make sure that the cable is not derailed from a pulley or rubbing on a cable trap.
11. Reattach the access cover and the tower cap.

CABLE DIAGRAM

The diagram below shows the proper routes of the cables. The numbers show the correct route of each cable. Use the diagram to make sure that the cables and the cable traps are assembled correctly. If a cable is not correctly routed, the strength equipment will not function properly and damage may occur. **Make sure that the cable traps do not touch or bind the cables.**

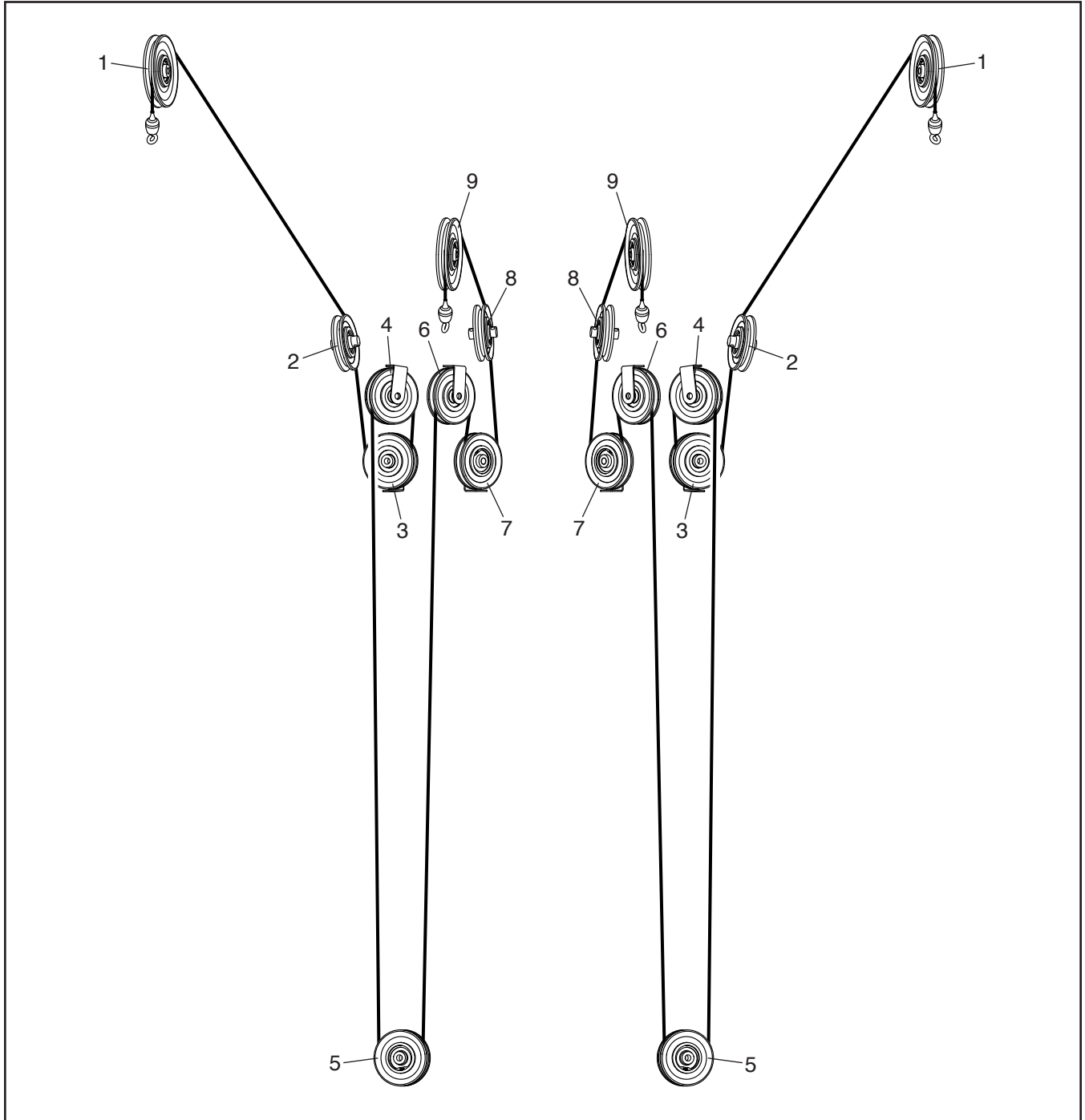

PART LIST

Model No. GD502.0 R0419A

Key No.	Qty.	Description	Key No.	Qty.	Description
1	2	Weight Carriage	43	4	Snap Ring
2	10	Medium Pulley	44	4	Roll Pin
3	2	Weight Carriage Cover	45	1	Tower
4	34	Weight	46	1	Center Pulley Frame
5	2	Weight Pin	47	1	Left Pulley Frame
6	8	Cable Trap	48	1	Right Pulley Frame
7	2	Weight Stack Cover	49	1	Seat Frame
8	4	Small Foot	50	1	Leg Frame
9	4	Weight Guide	51	1	Tower Brace
10	8	Weight Guide Spacer	52	2	Leg Pad
11	8	Plastic Washer	53	2	Wear Cover
12	4	Weight Bumper	54	1	Seat Pin
13	1	Tower Cap	55	1	Seat
14	1	M5 x 20mm Screw	56	3	#8 x 40mm Screw
15	4	Handle	57	2	Cable
16	4	Tower Cap Post	58	1	Leg Latch Spring
17	1	Access Cover	59	8	Carriage Bushing
18	4	Pulley Cover A	60	4	Small Pulley
19	4	Pulley Cover B	61	1	Seat Axle
20	8	Bearing	62	1	Seat Handle
21	4	Large Pulley	63	1	Leg Frame Pin
22	4	Pulley Cover Bushing	64	4	Pulley Axle
23	2	Weight Carriage Bumper	65	8	Pulley Spacer
24	1	Large Foot	66	2	Leg Pad Cap
25	4	Cable Eyelet	67	1	Seat Bumper
26	4	Cable Stop	68	1	Tower Trim
27	8	M6 x 16mm Screw	69	3	Trim Fastener
28	8	M5 x 15mm Screw	70	1	Leg Frame Sleeve
29	10	M10 x 50mm Bolt	71	1	Latch Handle
30	4	M10 x 40mm Bolt	72	2	Tower Bushing
31	10	M8 x 20mm Screw	73	1	Seat Spring
32	6	M6 x 10mm Screw	74	8	M5 x 25mm Screw
33	4	M4 x 30mm Screw	75	1	M5 x 27mm Screw
34	8	#8 x 13mm Screw	76	11	M12 x 20mm Screw
35	14	#6 x 10mm Screw	77	11	M10 x 20mm Screw
36	2	Weight Carriage Cover Bushing	78	4	M8 x 30mm Screw
37	8	M16 Jam Nut	79	1	M6 x 20mm Screw
38	8	M16 Split Washer	80	2	M6 x 25mm Screw
39	22	M10 Washer	81	8	M6 Washer
40	6	M6 Large Washer	82	2	M5 Locknut
41	4	M10 Thin Locknut	*	-	Owner's Manual
42	10	M10 Locknut			

Note: Specifications are subject to change without notice. For information about ordering replacement parts, see the back cover of this manual. *These parts are not illustrated.

EXPLODED DRAWING A

Model No. GD502.0 R0419A

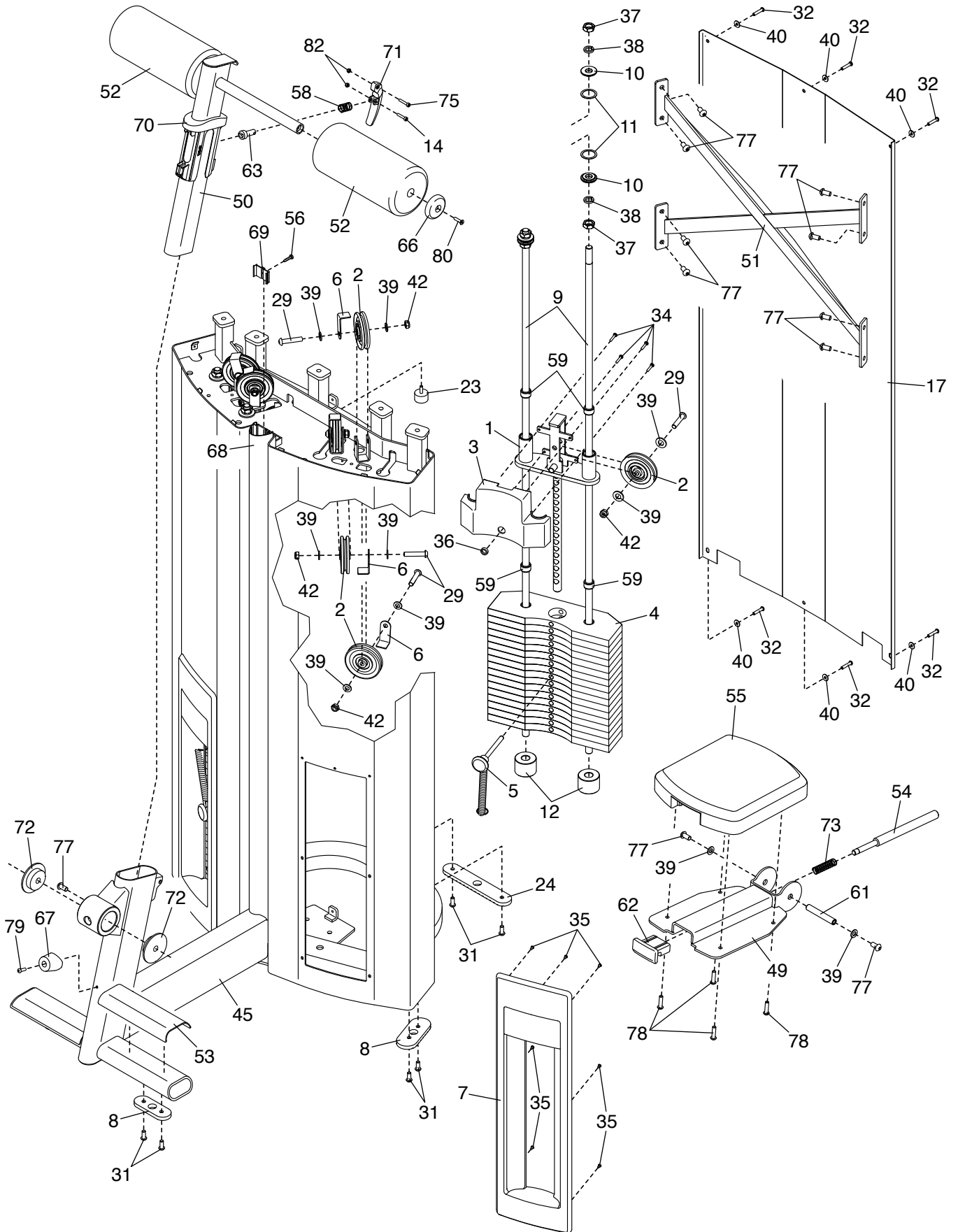

EXPLODED DRAWING B

Model No. GD502.0 R0419A

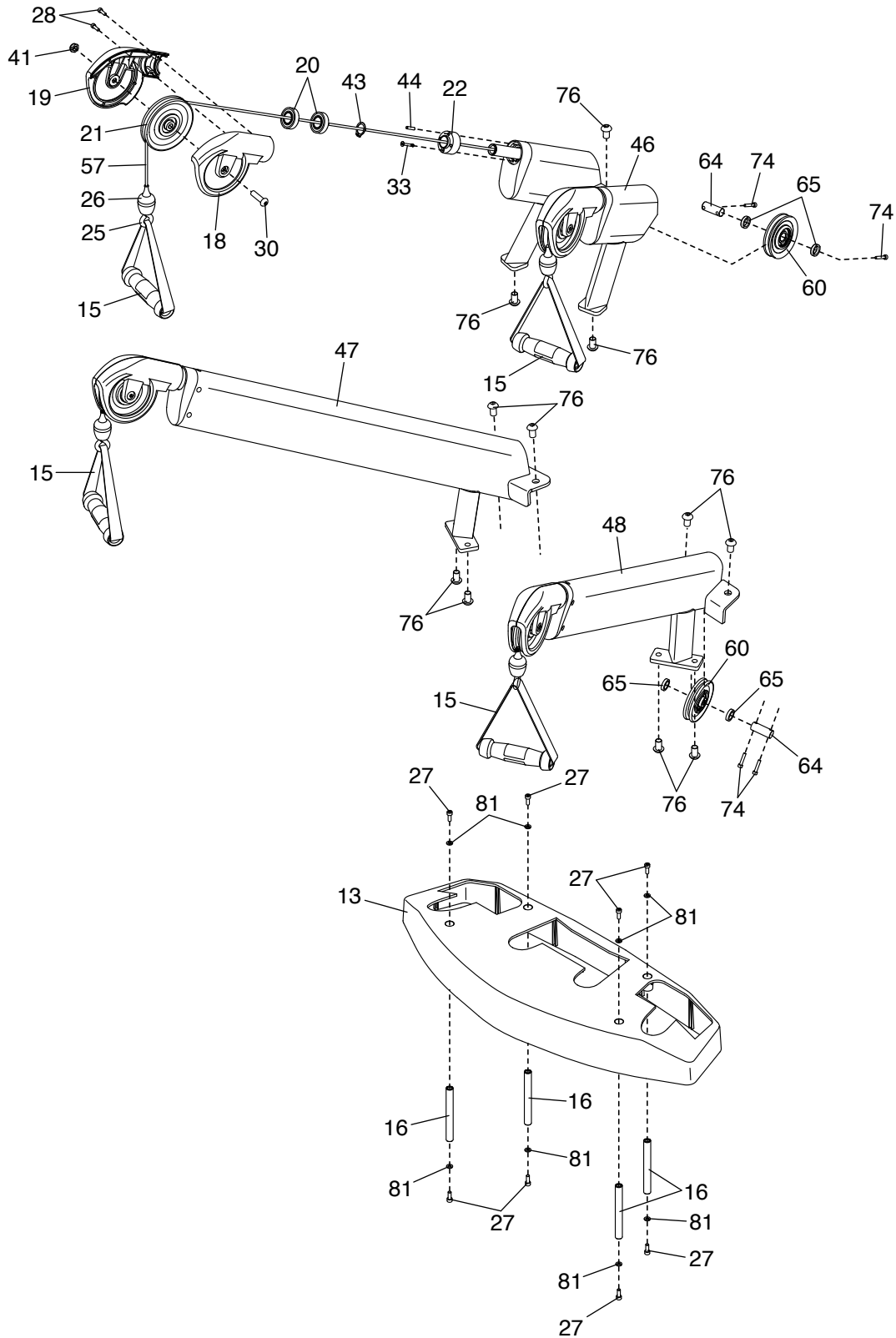

HOW TO CONTACT CUSTOMER CARE

If you have questions after reading this manual, or if parts are damaged or missing, please contact Customer Care at one of the phone numbers or addresses listed below. **Please note the model number, serial number, and name of the product (see the front cover of this manual) before contacting Customer Care. If you are ordering replacement parts, please also note the key number and description of each part (see the PART LIST and the EXPLODED DRAWING near the end of this manual).**

In the United States

Call: 1-800-201-2109, Mon.–Fri. 6 a.m.–6 p.m. MT

Email: customercare@freemotionfitness.com

Write:

Freemotion Fitness
1500 South 1000 West
Logan, UT 84321-9813
United States

Outside the United States

Call: 001-800-527-5417 or 001-435-786-3521,

Mon.–Fri. 6 a.m.–3 p.m. USA Mountain Time

Email: intlcustomercare@freemotionfitness.com

LIMITED WARRANTY

WARRANTY PERIODS AND COVERAGE

Freemotion Fitness warrants this product to be free from defects in workmanship and material under normal use and service conditions. Parts and labor are warranted for one (1) year, unless otherwise specified on the invoice.

The warranty period commences on the invoice date of purchase. Any parts repaired or replaced during this warranty period will be warranted for the remainder of the original warranty period.

CONDITIONS AND LIMITATIONS

The following will void the warranty on this product:

1. This warranty applies only to the original owner and is non-transferable.
2. The labor warranty applies only to products sold in the US and Canada. Contact your authorized Freemotion Fitness dealer for details on labor coverage in your country.
3. Any misuse, abuse, or improper service.
4. Users in excess of the maximum user weight listed in this manual. Note: This product may not have a maximum user weight.
5. Damage caused by moving the product or improper storage including moving or storing the product on its side.
6. Use or storage of the product outdoors or in high-humidity environments including spa and pool areas.
7. Damage caused by improper wiring or insufficient electrical current. Note: This product may not have wiring.

This warranty shall not apply to the following:

1. Cosmetic items including grips, decals, and labels.

2. Pick-up and delivery or freight charges involved with a repair.
3. Any problem as a result of improper assembly or delivery.

WHAT TO DO IF SERVICE IS REQUIRED

Freemotion Fitness warranty service may be obtained by contacting the authorized dealer from which you purchased this product. Make sure to retain your original invoice and serial number information. If this product experiences a failure under the warranty terms set forth, Freemotion Fitness shall provide at their option either repair, replacement, or refund of the purchase price. Freemotion Fitness compensates service providers for warranty trips within their service area. You may be charged additionally for service calls beyond this service area.

Freemotion Fitness is not responsible or liable for indirect, special, or consequential damages arising out of or in connection with the use or performance of the product; damages with respect to any economic loss, loss of property, loss of revenues or profits, loss of enjoyment or use, or cost of removal or installation; or other consequential damages. Some regions do not allow the exclusion or limitation of consequential damages. Accordingly, the above limitation may not apply to you. This warranty gives you specific rights, and you may have other rights that vary from region to region.

TO CONTACT FREEMOTION FITNESS

See HOW TO CONTACT CUSTOMER CARE above.